International Multidisciplinary Research Journal

Golden Research Thoughts

Chief Editor
Dr.Tukaram Narayan Shinde

Publisher
Mrs.Laxmi Ashok Yakkaldevi

Associate Editor
Dr.Rajani Dalvi

Honorary
Mr.Ashok Yakkaldevi

Welcome to GRT

RNI MAHMUL/2011/38595

ISSN No.2231-5063

Golden Research Thoughts Journal is a multidisciplinary research journal, published monthly in English, Hindi & Marathi Language. All research papers submitted to the journal will be double - blind peer reviewed referred by members of the editorial board. Readers will include investigator in universities, research institutes government and industry with research interest in the general subjects.

International Advisory Board

Flávio de São Pedro Filho Federal University of Rondonia, Brazil	Mohammad Hailat Dept. of Mathematical Sciences, University of South Carolina Aiken	Hasan Baktir English Language and Literature Department, Kayseri
Kamani Perera Regional Center For Strategic Studies, Sri Lanka	Abdullah Sabbagh Engineering Studies, Sydney	Ghayoor Abbas Chotana Dept of Chemistry, Lahore University of Management Sciences[PK]
Janaki Sinnasamy Librarian, University of Malaya	Ecaterina Patrascu Spiru Haret University, Bucharest	Anna Maria Constantinovici AL. I. Cuza University, Romania
Romona Mihaila Spiru Haret University, Romania	Loredana Bosca Spiru Haret University, Romania	Ilie Pintea, Spiru Haret University, Romania
Delia Serbescu Spiru Haret University, Bucharest, Romania	Fabricio Moraes de Almeida Federal University of Rondonia, Brazil	Xiaohua Yang PhD, USA
Anurag Misra DBS College, Kanpur	George - Calin SERITAN Faculty of Philosophy and Socio-Political Sciences AL. I. Cuza University, IasiMore
Titus PopPhD, Partium Christian University, Oradea,Romania		

Editorial Board

Pratap Vyamktrao Naikwade ASP College Devrukh,Ratnagiri,MS India	Iresh Swami Ex - VC. Solapur University, Solapur	Rajendra Shendge Director, B.C.U.D. Solapur University, Solapur
R. R. Patil Head Geology Department Solapur University,Solapur	N.S. Dhaygude Ex. Prin. Dayanand College, Solapur	R. R. Yaliker Director Managment Institute, Solapur
Rama Bhosale Prin. and Jt. Director Higher Education, Panvel	Narendra Kadu Jt. Director Higher Education, Pune	Umesh Rajderkar Head Humanities & Social Science YCMOU,Nashik
Salve R. N. Department of Sociology, Shivaji University,Kolhapur	K. M. Bhandarkar Praful Patel College of Education, Gondia	S. R. Pandya Head Education Dept. Mumbai University, Mumbai
Govind P. Shinde Bharati Vidyapeeth School of Distance Education Center, Navi Mumbai	Sonal Singh Vikram University, Ujjain	Alka Darshan Shrivastava Shaskiya Snatkottar Mahavidyalaya, Dhar
Chakane Sanjay Dnyaneshwar Arts, Science & Commerce College, Indapur, Pune	G. P. Patankar S. D. M. Degree College, Honavar, Karnataka	Rahul Shriram Sudke Devi Ahilya Vishwavidyalaya, Indore
Awadhesh Kumar Shirotriya Secretary,Play India Play,Meerut(U.P.)	Maj. S. Bakhtiar Choudhary Director,Hyderabad AP India.	S.KANNAN Annamalai University,TN
	S.Parvathi Devi Ph.D.-University of Allahabad	Satish Kumar Kalhotra Maulana Azad National Urdu University
	Sonal Singh, Vikram University, Ujjain	

Address:-Ashok Yakkaldevi 258/34, Raviwar Peth, Solapur - 413 005 Maharashtra, India
Cell : 9595 359 435, Ph No: 02172372010 Email: ayisrj@yahoo.in Website: www.aygrt.isrj.net



CHB MULTILEVEL INVERTER FED BLDC MOTOR POWERED BY MPPT CAPABLE P.V. PANELS

T. Hareesh¹ and V. V. Narasimha Murthy²

¹M-tech Student Scholar , Department of Electrical & Electronics Engineering,
University College of Engineering, JNT University-Kakinada; East Godavari (Dt); A.P., India.

²Assistant Professor & Head of the Department of Electrical & Electronics Engineering,
University College of Engineering, JNT University-Kakinada; East Godavari (Dt); A.P., India.

Abstract:-Cascaded Half-Bridge(CHB) multilevel inverter is a popular converter topology and has found widespread applications in industry, for instance, in high-power medium-voltage drives and reactive power compensating. In this, power cells are cascaded using two inverter legs in series. In the place of two parallel inverter legs, as used in CHB power cells. The Half-Bridge cells are usually connected in cascaded mode on their ac side to achieve medium-voltage operation and reduction of harmonic effect. Both IGBT/Diode switches are used in same leg with input voltage as $V_{dc}/2$. In this, Half-Bridge connection, half of the power is dissipated through the switches. The explosion severity of a power cell is reduced to half by this connection. The reliability of the system is improved and cost effectiveness. The phase shift pulse width modulating technique is used where five level cascaded Half-Bridge inverters are present.

MPPT stands for Maximum Power Point Tracking and it relates to the solar cell. Every solar cell has a point at which the current (I) and voltage (V) output from the cell delivers the maximum power output of the cell. The main principle here is the output from the solar cell can be regulated to the voltage and current levels needed to achieve a power output at this point, the power generated by the solar cell will be used most efficiently This MPPT concept is included in the proposed converter. (PV) power systems are getting more and more widespread with the increase in the energy demand and the concern for the environmental pollution around the world. Multilevel inverters (MLI) have gained much attention in the area of energy distribution and control due to its advantages in high power applications with low harmonics. Out of many structures of MLIs, cascaded H Bridge (CHB) MLI is more suitable converter for PV applications since each PV panel can act as a separate DC source for each CHB module. The performance of asymmetrical and symmetrical single phase CHB multi level inverter configurations are simulated by using MATLAB/Simulink software.

Keywords:Inverters, cascade systems, multilevel systems, PWM, MPPT.

INTRODUCTION :

The BLDC motors have been widely used for various industrial application based on inherent advantages. These are most suitable motors in application field which require fast dynamic response of speed, because of their high efficiency and can be easily controlled in a wide speed range. This is relatively new class of motors whose application have been increasing at a rapid rate each year, due to declining costs as well as increasing functionality. For driving the BLDC motor we require inverter, because of powerful actuators in small sizes for industrial applications. DC motors are gradually get replaced by BLDC motors as compared to same-output-rating DC motors. BLDC motors are having less maintenance due to the lack of commutator and have a high-power density which is

ideal for high torque-to-weight ratio applications.

Multilevel inverters [1]-[2] have been attracting wide industrial interests. It is considered an most effective alternative to reduce switching stress. The main characteristic of these converters is that they provide an output waveform with many voltage levels. In recent decades, an extensive array of multilevel structures has appeared for instance in the Cascaded H-bridge (CHB) Neutral point clamped (NPC) and Flying capacitor (FC) [17]-[18]. Cascaded H-bridge multilevel inverter is a popular converter topology and has found widespread applications in industry [3], for instance, in high-power medium-voltage drives and reactive power compensating [4]-[7]. It is composed of multiple units of single-phase H-bridge power cells, using two inverter legs in parallel powered by isolated dc supply. The inverter dc bus voltage is usually fixed, while the adjustable ac output voltage can be obtained by modulation schemes.

A small size of photovoltaic (PV) system; starts up from a few hundred watts to a few kilowatts, is more and more adopted in households due to attention of global warming and energy conservation. However, output power of PV array is directly affected by two uncontrollable parameters, i.e. Sun radiation or irradiance (W/m^2) and ambient temperature ($^{\circ}C$). Consequently, output power of PV array has widely variations as In order to obtaining full utilization of PV system, a high efficiency converter operated with a high performance algorithm of maximum power point tracking (MPPT) [19]-[22].

II. PROPOSED CONCEPT

A) Incremental conductance method for MPPT

In the incremental conductance method, the controller measures changes in array current and voltage to predict the effect of incremental voltage change. This method requires excess number of computation in the controller, but more rapid changing conditions can be tracked than the perturb and observe (P&O) method. Like the P&O algorithm, it can produce oscillations in power output. In this method the incremental conductance (dI/dV) of the photovoltaic array is utilized to compute the sign of the change in power with respect to voltage (dP/dV). The incremental conductance method computes the maximum power point by comparison of the incremental conductance (I/V) to the array conductance (dI/dV). When these two are the same ($I/V = dI/dV$) the output voltage is the Maximum Power Point voltage. The controller maintains the same voltage until the irradiation level is get changed and the process is repeated.

$$dI/dV = -I/V \text{ at mpp}$$

$$dI/dV > -I/V \text{ left of mpp}$$

$$dI/dV < -I/V \text{ right of mpp}$$

Where I and V are the PV array output current and voltage, respectively. The LH-Side of the equations represents the Incremental Conductance of the PV module, and the RH-side represents the instantaneous conductance. This is shown in fig 1, it is obvious that when the ratio of change in the output conductance is equal to the negative output conductance, the solar array will operate at the MPP. In other words, by comparing the conductance at each sampling time, the MPPT will track the maximum power of the PV module, and solar cell deliver the maximum power.

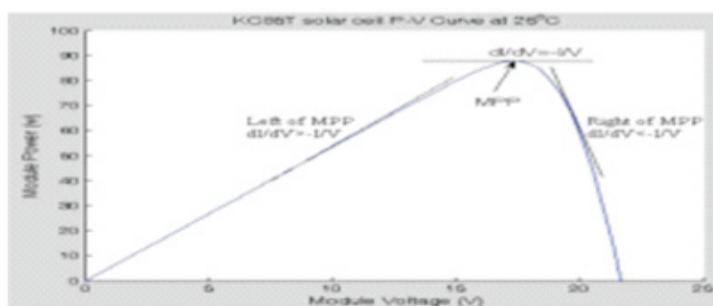

Fig. 1 Basic idea of the IncCond method on a P-V curve of a solar module

A number of photovoltaic cells electrically connected to each other and mounted in a single support structure or frame is called a 'photovoltaic module'. Several modules can be wired together to form an array. Photovoltaic modules and arrays produce direct-current electricity. They can be connected in both parallel and series electrical arrangements to produce any required voltage and current combination.

In this paper among all MPP Technologies, Incremental conductance method is used to obtain our required voltage. BLDC electric motors are powered by a DC electric source which was generated by using a PV Panel, via an

cascaded H-Bridge inverter, which produces an AC electric signal to drive the motor.

B) Cascaded H-Bridge Inverter

“H” topology has many redundant combinations of switches’ positions to produce the same voltage levels. The cascaded H-bridge multilevel Inverter uses separate dc sources (SDCSs). The multilevel inverter using cascaded-inverter with SDCSs synthesizes a desired voltage from several independent sources of dc voltages.

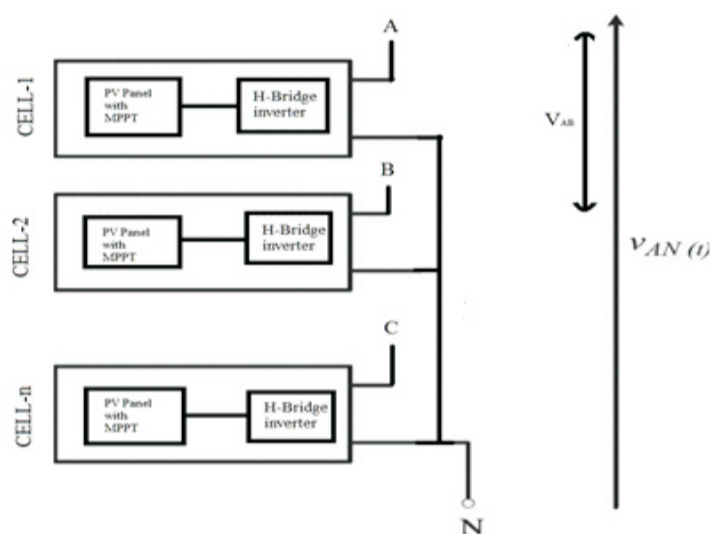

Fig 2: The basic cell structure of multilevel inverters fed to BLDC drive

Some works comparing between different Multilevel inverters topologies have shown that H-bridge inverter is the most suitable for photovoltaic systems. This work presents a study from quality standpoint of voltages generated by PV Panel using cascaded H-Bridge inverters. The basic component of these inverters is a cell called H-bridge. These inverters are controlled by the PWM control law and have different levels (3L, 5L and 9L). The goal is to achieve high efficiency of the generated voltage.

Figure 2 illustrates the basic cell structure of multilevel inverters. Each bridge has four power switches. The cell supply is provided by a photovoltaic panel with a rated voltage of 48V. In this study, we will not consider any stage between the PV panel and the H-bridge. For topologies with multiple cells in this paper Star connection three-phase system is used to increase the output voltage of the inverters.

The number of levels in the output voltage depends on the number of cells:

$$N = 2C + 1 \quad \text{---(1)}$$

Where N: number of levels

C: number of cells

By selecting proper switching functions, zero, negative, and positive voltages can be synthesized. The output voltage V_O is the sum of the output voltage produced by each Half-bridge cell. Hence, every Half-bridge module requires an independent voltage source.

III.PHASE SHIFT PULSE WIDTH MODULATION

In this converter, the PWM phase-shifted multicarrier modulation technique was used. Same frequency triangular carriers are used, hence there is the same peak-to-peak amplitude with a phase shift between any two adjacent carrier waves. This is done to increase the harmonic cancellations. The definition of a phase shift is shown in equation (2). By this equation the harmonics get optimized and will get cancelled.

For an inverter with two power cells in cascade, it is necessary to employ four triangular carriers with phase shifts of $0, \pi/2, \pi$ and $3\pi/2$.

$$\frac{(k-1)\pi}{N_c} \quad k = 1, 2, \dots, 2N_c \quad -(2)$$

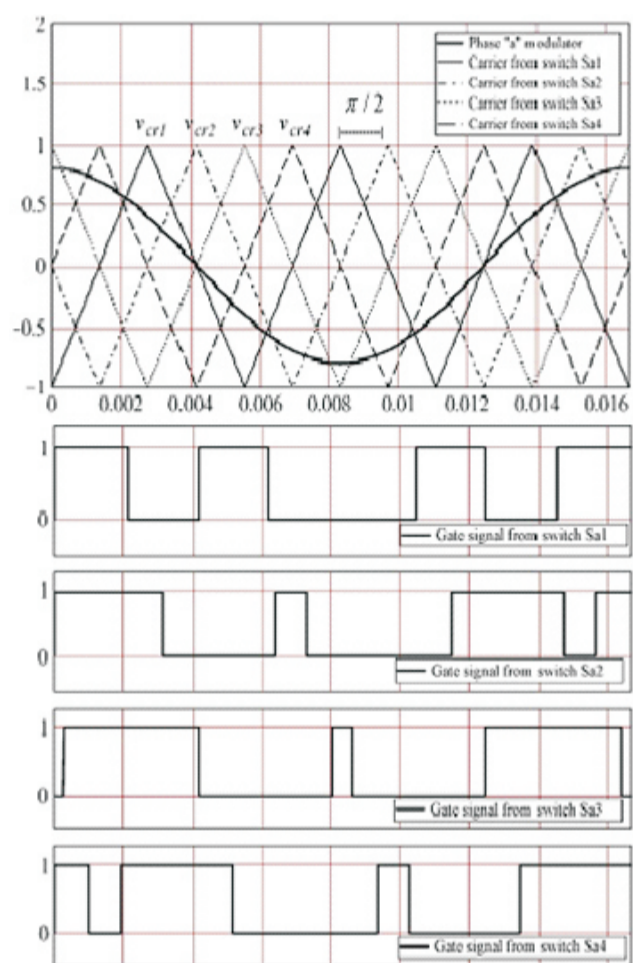

Fig.3. Simulated waveform of the proposed multilevel inverter

Only the upper switch-gate signals for one phase are presented in Fig.3, because the lower switch-gate signals are Complementary. The other two phases are shifted by $\pm 120^\circ$. To obtain the switch-gate signals a comparison between the triangular carriers and the modulator is carried out as indicated in Fig.3. The resultant signal will be high when the instantaneous value of the sinusoidal wave exceeds the triangular carrier, otherwise, it will be null. The duration of each pulse width in the output comparator depends therefore on the time that the sine wave remains above the value of the triangular wave. These high-frequency pulses are sent to the switches of the circuit in Fig. 4, with four inverter legs in cascade.

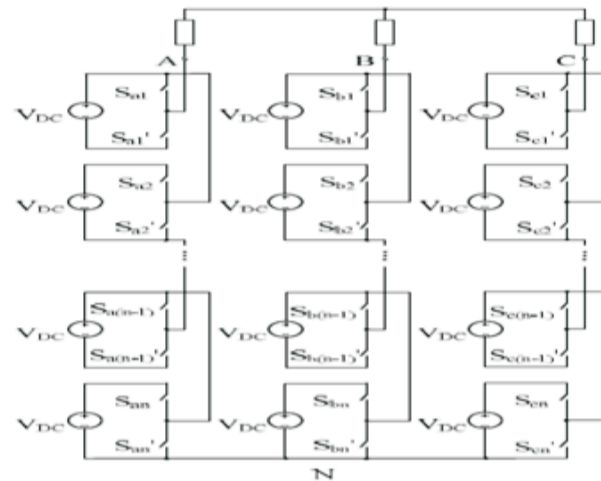

Fig.4. Multilevel inverter four inverter legs in cascade.

The carrier waveforms employed in these modulation techniques are usually triangular or saw tooth. In this study there is an requirement for reduction in harmonic content, hence Triangular unipolar format was used over the saw tooth carrier. Triangular carriers in general has a fixed scale, so the Fundamental magnitude control of the output voltage is achieved by varying the sinusoidal modulator amplitude. This alters the pulse widths which results a change in the output voltage amplitude.

In Fig. 5 the modulation schematic for one phase is presented. All comparators share the same modulator waveform and each unipolar triangular carrier has a shift.

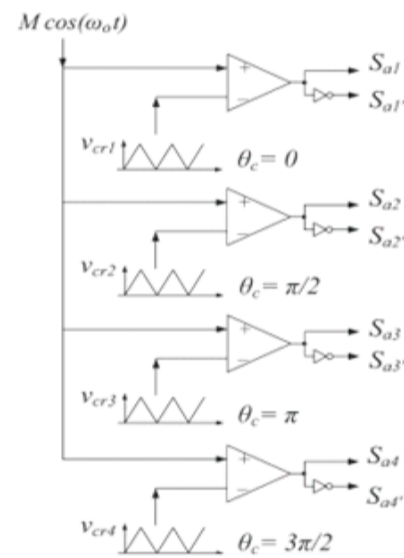

Fig.5. Simplified modulation schematic

Phase-shift modulation described here, is similar as the one used in CHB multilevel inverter. A CHB multilevel inverter with nP voltage levels requires $(nP - 1)$ triangular carriers. In the phase-shifted multicarrier modulation, all the triangular carriers have the same peak-to-peak amplitude and the same frequency with a phase shift between any two adjacent carrier waves, however, the phase-shift between two parallel inverter legs of each power cell must be 180° .

IV.SIMULATION RESULTS

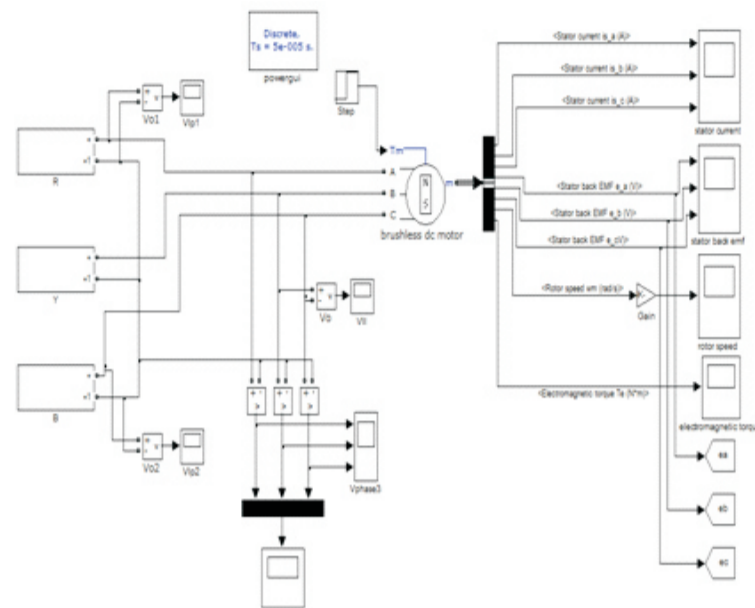

Fig.6. Simulink model of proposed Half Bridge power cells fed BLDC motor

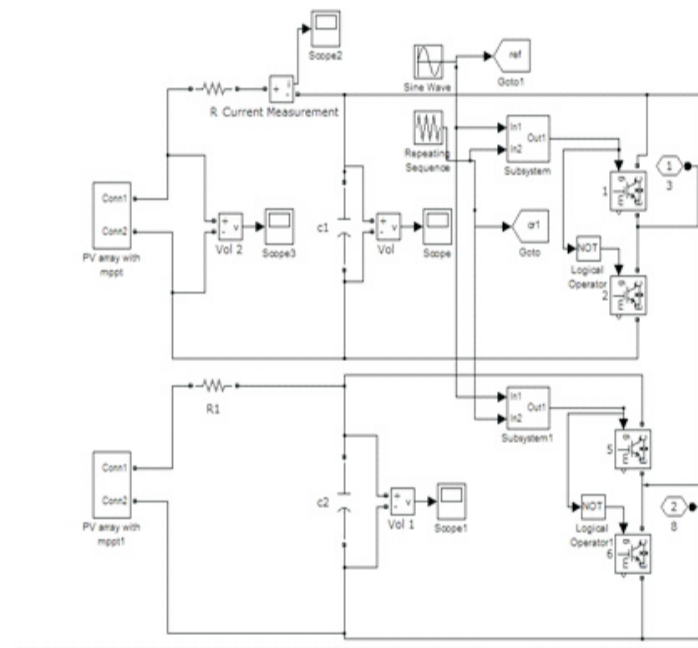

Fig. 7. Simulink diagram of PV array with MPPT connected as input

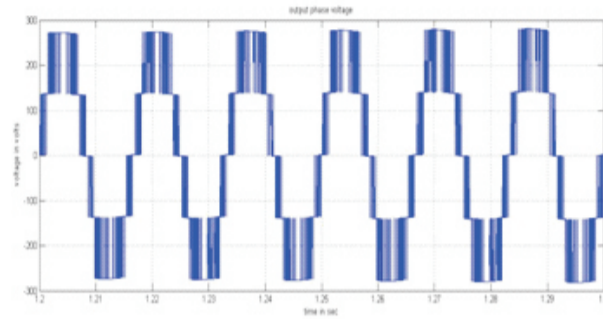

Fig.8. Output 5 level phase voltage

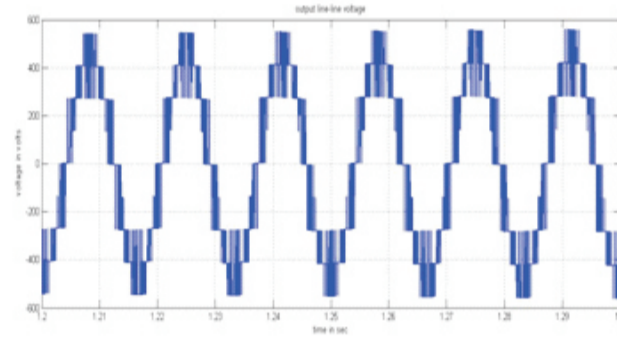

Fig.9. Output 9 level line to line voltage

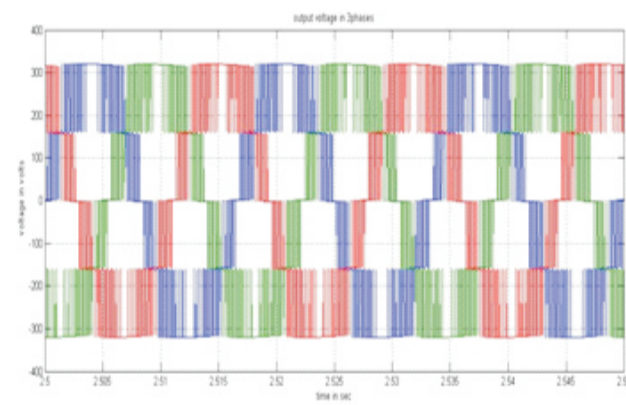

Fig .10. Output voltages of each phase

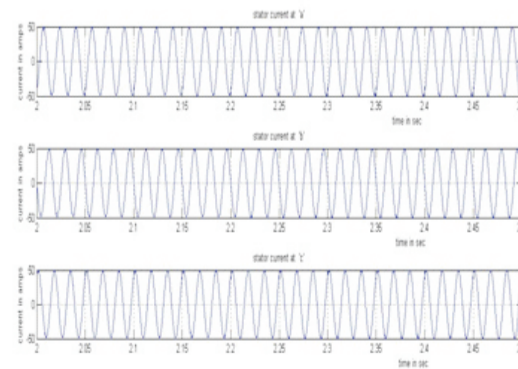

Fig .11. Three phase stator current

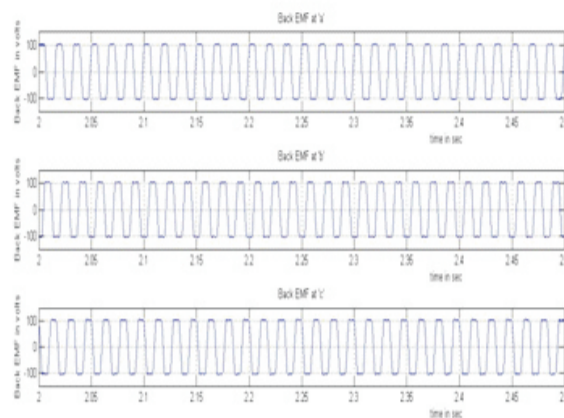

Fig. 12. Stator Back-EMF in each phase

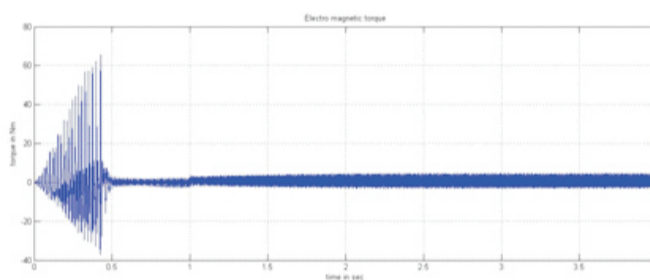

Fig.13. Generated torque of the 5-level proposed multilevel inverter fed BLDC motor

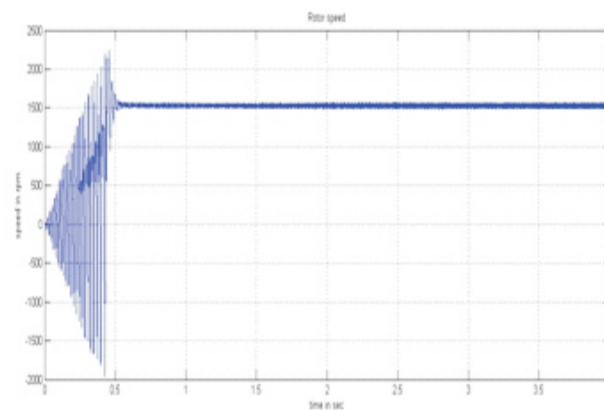

Fig.14. Output rotor Speed for BLDC motor drive

V.CONCLUSION

The design of the PV with MPPT capability using phase shift pulse width modulating technique are carried out for five level cascade Half-Bridge inverter topology fed BLDC motor drive and the simulation results are presented for the performance of MPP Tracked PV Panel, BLDC motor and analytical equation for line to line and phase voltages where developed.

In this proposed topology maximum power is achieved for PV Panel by using MPP Tracking. input voltage is $V_{dc}/2$ short circuit of same leg means that half of power fritters away from it and is easy to reinstate that leg which decreases the cost. MATLAB/Simulink model is developed and simulation results are presented. it is observed that the efficiency of the converter is improved.

REFERENCES

- [01]G. Walt rich, I. Barbi, "Three Phase Cascaded Multilevel Inverter using Power Cells with two Inverter legs in Series" IEEE Trans. On Ind. Electronics, Vol.57, no.8. Aug.2010.
- [02] Brushless DC (BLDC) Motor in www.microchip.com
- [03]C. H. Chen and M. Y. Cheng, "Implementation of a highly reliable hybrid electric scooter drive," IEEE Trans. Ind. Electron., vol. 54, no. 5, pp. 2462–2473, Oct. 2007.
- [04]John T. Lee, Carlos Ribeiro, and Miguel Mendoza "Designing High-Performance and Power Efficient 3-Phase Brushless DC Motor Control Systems" in Micrel, Inc.apr,2014
- [05]Michał KNAPCZYK, Krzysztof PIENKOWSKI "ANALYSIS OF PULSE WIDTH MODULATION TECHNIQUES FOR AC/DC LINE-SIDE CONVERTERS" in Studia i Materiały, Nr 26, 2006
- [06]J. Goetz, W. Hu, and J. Milliken, "Sensorless digital motor controller for high reliability applications," in Proc. IEEE APEC, 2006, pp. 1645–1650.
- [07]Sandeep Kumar Singh, Harish Kumar, Kamal Singh, Amit Patel "A Survey And Study Of Different Types Of Pwm Techniques Used In Induction Motor Drive" in IJESAT Volume-4, Issue-1, 018-122 Jan-Feb 2014.
- [08]K.H. Park, T.S. Kim, S.C. Ahn and D.S. Hyun "Speed Control of High-Performance Brushless DC Motor Drives by Load Torque Estimation," Power Electronics Specialist Conference, 2003. PESC '03. 2003, vol. 4, no. 5, 2003, pp. 1677–1681.
- [09]S. Saravana Kiruthiga, S. Rajasekaran, "A Cascaded Dual Buck Half-Bridge Inverter for Efficient PowerFlow Control in Grid" in IOSR-JEEE, aug 2011.
- [10]J. Rodriguez, S. Bernet, B. Wu, J. O. Pontt, and S. Kouro, "Multi-level voltage-source-converter topologies for industrial medium-voltage drives," IEEE Trans. Ind. Electron., Vol. 54, No. 6, pp. 2930–2945, Dec. 2007.
- [11]Dr. Keith Corzine "Operation and Design of Multilevel Inverters" Developed for the Office of Naval Research.
- [12]B. Lin and H. Lu, "New multilevel rectifier based on series connection of H-bridge cell," Proc. Inst. Elect. Eng. Electron. Power Appl., vol. 147, no. 4, pp. 304–312, Jul. 2000.
- [13]S. G. Song, F. S. Kang, and S. J. Park, "Cascaded multilevel inverter employing three-phase transformers and single dc input," IEEE Trans. Ind. Electron., vol. 56, no. 6, pp. 2005–2014, 2009.
- [14]Matthew Senesky, Hao Qian, Kosha Mahmodieh, Shahradd Tabib "Battery Module Balancing with a Cascaded H-Bridge Multilevel Inverter" in White Paper altairnano.mar 2012
- [15]What is Maximum Power Point Tracking (MPPT) and How Does it Work?, Fortune Way, Suite K, www.blueskyenergyinc.com
- [16]M. Kavitha, A. Arunkumar, N. Gokulnath, S. Arun "New Cascaded H-Bridge Multilevel Inverter Topology with Reduced Number of Switches and Sources" in iosrjournals.org apr. 2013
- [17]C. Newton and M. Summer, "Novel technique for maintaining balanced internal DC link voltages in diode-clamped five-level inverters," Proc. Inst. Elect. Eng. Electron. Power Appl., Vol. 146, No. 3, pp.341–349, May 1999.

Publish Research Article International Level Multidisciplinary Research Journal For All Subjects

Dear Sir/Mam,

We invite unpublished Research Paper, Summary of Research Project, Theses, Books and Book Review for publication, you will be pleased to know that our journals are

Associated and Indexed, India

- * International Scientific Journal Consortium
- * OPEN J-GATE

Associated and Indexed, USA

- EBSCO
- Index Copernicus
- Publication Index
- Academic Journal Database
- Contemporary Research Index
- Academic Paper Database
- Digital Journals Database
- Current Index to Scholarly Journals
- Elite Scientific Journal Archive
- Directory Of Academic Resources
- Scholar Journal Index
- Recent Science Index
- Scientific Resources Database
- Directory Of Research Journal Indexing

Golden Research Thoughts
258/34 Raviwar Peth Solapur-413005, Maharashtra
Contact-9595359435
E-Mail-ayisrj@yahoo.in/ayisrj2011@gmail.com
Website : www.aygrt.isrj.net